



# Electromagnetic Brake Motor

## 90 Watt

Square Flange  
90mm x 90mm

Continuous Rating with Frequent Start Stop, Load Holding & Minimum Overrun.  
Electromagnetic Fail Safe Brake (Power Off Activated) fitted at the Back of Induction Motor.  
Rotates in Clockwise or Counter Clockwise Direction.  
Terminal Box or Lead Wires for connection.



### Motor Specifications:

Model	Supply	Freq. Hz	Stall Torque Nm	Rated Torque Nm	Rated Speed RPM	Rated Current Amp	Cap. $\mu$ F
5EX4□90	Single Phase 230V	50	0.86	0.62	1350	0.51	4
5EY4□90	Three Phase 230V	50	0.86	0.72	1250	0.44	-
5EY4□90	Three Phase 415V	50	1.10	0.61	1350	0.25	-
5EX2□90	Single Phase 230V	50	0.45	0.34	2700	0.46	2.5
5EY2□90	Three Phase 230V	50	0.39	0.33	2600	0.47	-
5EY2□90	Three Phase 415V	50	0.56	0.34	2700	0.26	-

□ Indicates type of Shaft, G - Gear, R - Round, F - Frame, C - Custom

### Gearmotor Torque Table:

The maximum permissible torque is 20 Nm  
No Load speed of Motor at 50Hz is approx. 1440RPM

50Hz Unit : Nm

RPM	480	400	288	240	192	160	115	96	80	57	48	40	29	24	19	16	14	12	9.6	8
Gear Ratio	3	3.6	5	6	7.5	9	12.5	15	18	25	30	36	50	60	75	90	100	120	150	180
Output Torque	1.7	2.0	2.8	3.3	4.2	5.0	6.3	7.5	9.1	11.2	13.4	16.1	20.0	20.0	20.0	20.0	20.0	20.0	20.0	20.0

The Gear boxes are sold separately.  
A coloured background indicates gear shaft rotation in same direction as motor shaft.  
A white background indicates gear shaft rotation in opposite direction to the motor shaft.  
The speed of geared motor is calculated by dividing motor's no load speed by the gear ratio.  
The actual speed is less than the displayed value, depending upon the load.  
Characteristics, specifications and dimensions are subject to change without notice.

## Dimensions:

### Motor, Gearbox with Terminal Box

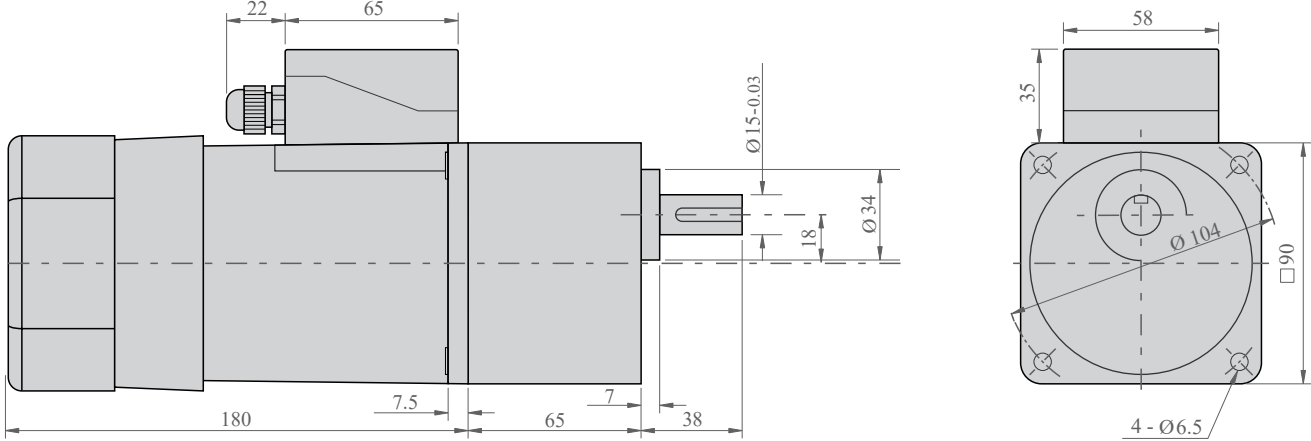

### Motor Round Shaft with Terminal Box

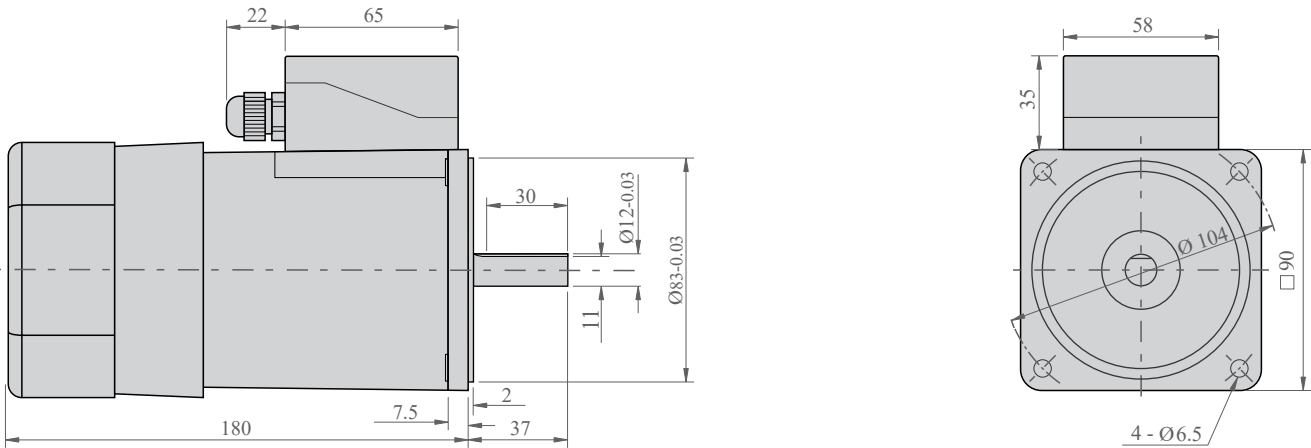

### Motor, Gearbox with Lead Wires

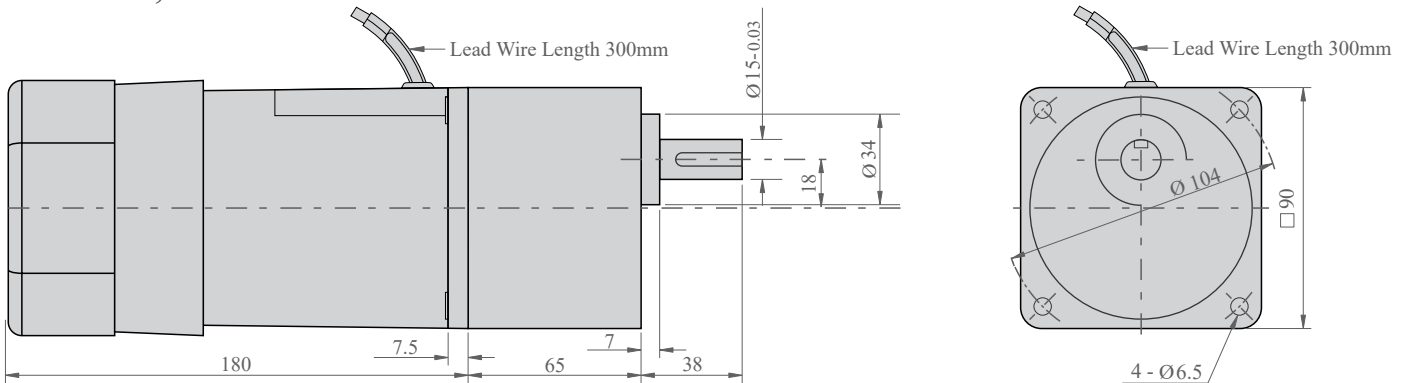

### Key & Keyway

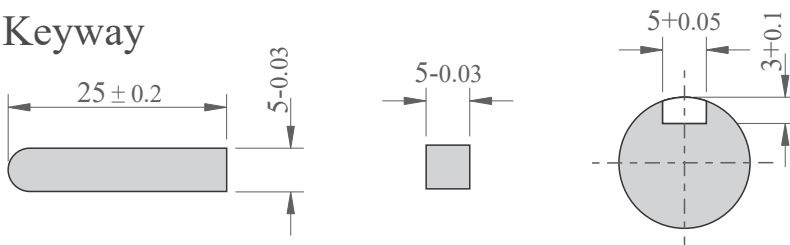

Max. Weight:  
 Motor - 4.2 kg  
 Gear Box - 1.7 kg

# Electromagnetic Brake Motor

## Wiring Diagrams:

### Wiring Diagram for Single Phase Motor

	<p>When SW1 is switched ON, Electromagnetic Brake is released &amp; motor starts rotating. When SW1 is switched OFF then Electromagnetic Brake will be applied stopping the motor immediately &amp; holding the load.</p> <p>Apply voltage on the orange brake lead wires only, to release the Electromagnetic Brake.</p> <p>To change the direction of rotation, flip CW to CCW.</p>
--	---

### Wiring Diagram for Three Phase Motor

	<p>When SW1 is switched ON, Electromagnetic Brake is released &amp; motor starts rotating. When SW1 is switched OFF then Electromagnetic Brake will be applied stopping the motor immediately &amp; holding the load.</p> <p>Apply voltage on the orange brake lead wires only, to release the Electromagnetic Brake.</p> <p>To change the direction of rotation, interchange any two wires between U, V &amp; W.</p>
--	---

Change the direction of motor only after it stops rotating. If the attempt is made during rotation, motor may not change the direction or change the direction after some time.